

ELECTRO-SENSORS

Superior • Systems • Solutions



M-Series

PVC-Series



M100/M5000 & PVC100/PVC5000 Miniature Speed Switch Series

- Compact, self-contained system with sensor and switch
- Easy installation and calibration
- Rugged system is dust, dirt and greaseproof
- Explosionproof cast aluminum housing (M100/M5000)
- PVC corrosion-resistant NEMA 4X housing (PVC100/PVC5000)
- M-Series is UL and CSA approved to applicable standards
- Fail-safe operation
- 5-Year Limited warranty on speed switches, sensors and ratemeters*

* Consult factory for more information

Product Information

Description

M-Series and PVC-Series Miniature Speed Switches are self-contained rotation monitoring systems that are ideal for detecting the unwanted slowdown of process equipment. These systems are commonly used to monitor drive trains, power-driven components, crushers, exhaust fans, screw conveyors, or tail pulleys on belt conveyors and elevators. The standard system includes either an M-Series or PVC-Series switch and a 255 Pulsar disc. Electro Sensors' speed switches bring efficiency and safety to your operations by preventing machine damage, product waste and costly downtime.

Principle of Operation

Miniature Speed Switches contain a sensor and switching electronics in either a heavy duty, explosionproof cast aluminum housing (M-Series) or a chemical/corrosion resistant PVC housing (PVC-Series). Each switch is supplied with a shaft-end mounted Pulsar Disc (or optional Split Collar Pulsar Wrap) which generates an alternating magnetic field that is picked up by the speed switch. The switch decodes this frequency signal to determine shaft speed and compares this to the pre-adjusted set point, easily calibrated via a single-turn potentiometer. In the event of rotational failure, such as a broken drive, belt slippage, product overloads or clogs, the relay can be used to provide an alarm or equipment shutdown, assuring machine protection and process integrity. The Miniature Speed Switch Series is fail-safe; any malfunction during operation will de-energize the control circuit.

Dimensional Drawings • M-Series & PVC Series

M100/M5000

M100 Stock No. 775-007700
M5000 Stock No. 775-007800

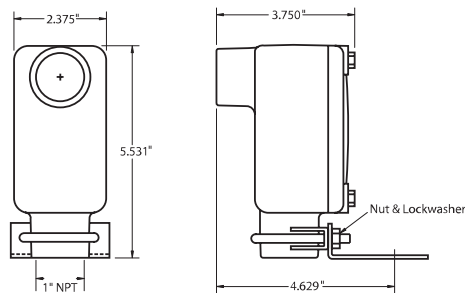

PVC100/PVC5000

PVC100 Stock No. 775-007710
PVC5000 Stock No. 775-007810

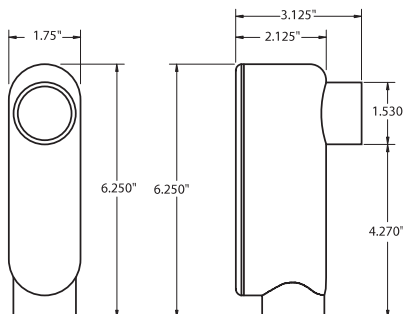

255 Pulsar Disc (M100/PVC100)

Stock No. 700-000200

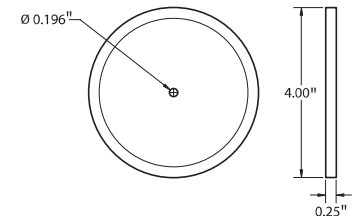

256 Pulsar Disc (M5000/PVC5000)

Stock No. 700-000300

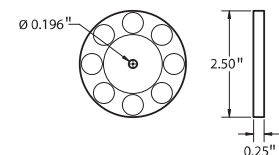

M & PVC Series Miniature Speed Switch

Large-Gap Switch Installation

M-Series Speed Switches are supplied with a slotted mounting bracket, which is easily adjustable to achieve the proper gap distance. PVC-Series Speed Switches are designed to receive a 1" conduit fitting. Care should be taken when installing these switches to ensure the proper gap distance is achieved. All switches should be installed allowing the center of the magnets to pass in front of the center of the sensing head during rotation. The gap distance between the sensor and disc or wrap (dimension A in figures 1 and 2) is $1/4" \pm 1/8"$.

Speed Switch and Disc
Figure 1

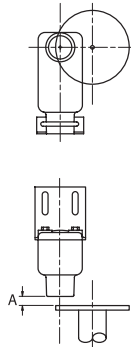

Speed Switch and Wrap
Figure 2

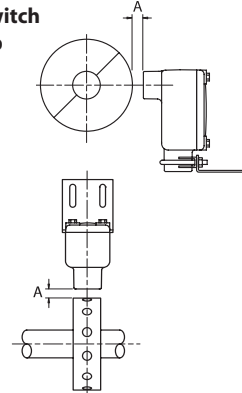

Switch Selection Guide

Refer to the Switch Selection Chart to determine which model is appropriate for your application. The primary difference between the M100/PVC100 and the M5000/PVC5000 is the set point range. The actual operating speed of the monitored shaft is not the critical factor when selecting which model to use, it is the desired set point speed at which the relay is to energize and de-energize. The M100/PVC100 can be adjusted to trip from 10 to 100 rpm. The M5000/PVC5000 can be adjusted to trip from 100 to 5000 rpm. For more assistance in selecting a switch consult an Electro-Sensors Application Specialist.

Switch Selection Chart

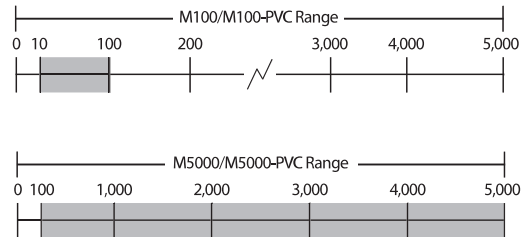

Available Options

- Split Collar Pulser Wrap for when end of shaft is inaccessible. Wraps available in the following materials:
 - PVC
 - Aluminum
 - Stainless Steel
- EZ100 Easy Mount Bracket Assembly for use with M-Series switches (See figure 3)
- Stainless Steel Disc-Guards available for M-Series

Optional EZ100 Easy Mount Bracket
Figure 3

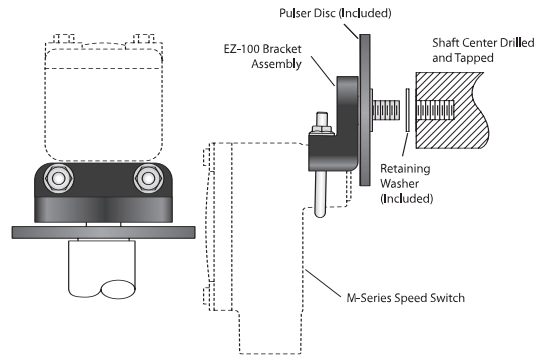

Miniature Speed Switch Specifications

Input Power

Voltage 115Vac, 60 Hz standard

Sensor Input Signal

Type NPN Open Collector
Set Point Relay SPDT, Isolated, 5 Amp, 115 Vac resistive
Set Point Adjustment Single turn (270°) Potentiometer
Sensing Head Integral

General Specifications

M100/M5000 Cast Aluminum, CSA Approved, Meets UL Class I, Group D; Class II, Groups E, F, G; Class III

PVC100/PVC5000	Poly Vinyl Chloride (PVC). UL and CSA approved
Gasket	Provided for waterproofing • Optional on M100/M5000 (cancels explosionproof rating) • Standard on PVC Switches
255 Pulser Disc	Nylon® 12, 4" diameter, 16 magnetic poles (use with M100 & PVC100)
256 Pulser disc	PVC 2-1/2" diameter, 8 magnetic poles (use with M5000 & PVC5000)
Gap Distance	1/4" ± 1/8"
Operating Temperature	-40° C to + 60° C *

* Contact factory for higher temperature ranges. Specifications subject to change without notice.